

SL6+ Manual

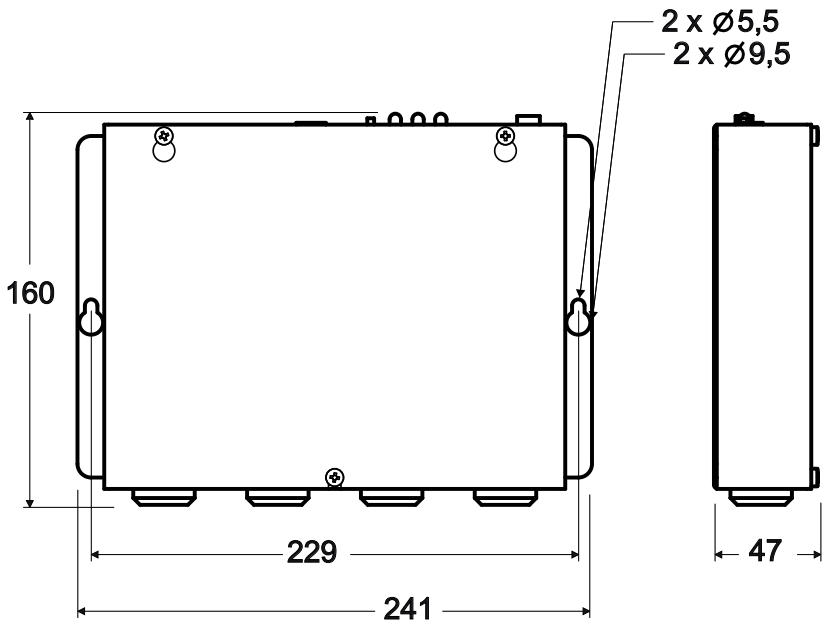

Content

Overview

Description of the Bus System	6
System Overview	6

Installation

Overview SL6+ Main Unit	7
Overview SL6+ Voice Unit	8
Other Components	10
Mounting	11
Wiring Diagram SL6+ Main Unit	12
Wiring Diagram Voice Unit	13
Wiring Diagram Voice Unit Screw Terminals	14
Connecting the Telephone Line	14
Activating the SIM Card	15

Startup

LED Indication Front Panel	16
LED Indication for Pictogram in Car	17
Startup Procedure	18

Configuration

CONNECT	19
Configuration with PC	20
Configuration with Telephone	21
Remote Configuration with Telephone	22
On-Site Configuration with Telephone	24
Configuration Examples	25
Parameter List	26
Relay Functions	33

Operating

Calling with SafeLine SL6+	34
Intercom between Main Station and Voice Unit	34
Outgoing Call	34
Emergency Calling Process	35
Incoming Call Process	36
Fallback	37
Fire Mode	38

Service

Battery Function	39
Troubleshooting Main Unit	40
Troubleshooting Voice Unit	41
Related Test Procedures	42

Certificate

Declaration of Conformity	43
---------------------------	----

General Information

General information

This unit was built with state-of-the-art technology and to generally recognised safety related technical standards currently applicable. These installation instructions are to be followed by all people working with the unit, in both installation and maintenance.

It is extremely important that these installation instructions are made available at all times to the relevant technicians, engineers or servicing and maintenance personnel. The basis prerequisite for safe handling and trouble free operation of this system is a sound knowledge of the basic and special safety regulations concerning conveyor technology, and elevators in particular.

The unit may only be used for its intended purpose. Note in particular that, no unauthorised changes or additions may be made inside the unit or individual components.

Exclusion of liability

The manufacturer is not liable with respect to the buyer of this product or to third parties for damage, loss, costs or work incurred as a result of accidents, misuse of the product, incorrect installation or illegal changes, repairs or additions. Claims under warranty are likewise excluded in such cases. The technical data is the latest available. The manufacturer accepts no liability arising from printing errors, mistakes or changes.

Declaration of conformity

Download "The declaration of conformity" at our website: www.safeline-group.com

Safety Precautions!

- Only trained professionals, who are authorised to work on the equipment, should install and configure this product.

- This quality product is dedicated for the lift industry. It has been designed and manufactured to be used for its specified purpose only. If it is to be used for any other purpose, SafeLine must be contacted in advance.

-It should not be modified or altered in any way, and should only be installed and configured strictly following the procedures described in this manual.

- All applicable health and safety requirements and equipment standards should be considered and strictly adhered to when installing and configuring this product.

- After installation and configuration this product and the operation of the equipment should be fully tested to ensure correct operation before the equipment is returned to normal use.

Electrical and electronic products may contain materials, parts and units that can be dangerous for the environment and human health. Please inform yourself about the local rules and disposal collection system for electrical and electronic products. The correct disposal of your old product will help to prevent negative consequences for the environment and human health.



SafeLine SL6+

Technical Data Main Unit

Power	Supply voltage: 230 VAC min: 6,4 W, max: 9,4 W
Battery	Battery voltage: 12 VDC lead battery Capacity: 1,2 Ah Charge: 13,65 VDC, max. 200 mA
Emergency light	Emergency light output: 12 VDC max 500 mA
Emergency signal	Acoustic emergency signal output: 12 VDC max 200 mA
Inputs	10-30 VDC, 5 mA, optically isolated
Antenna connector	SMA (female)
Size	SL6+: 241 x 160 x 47 mm (L x W x H) SL6+ Mini: 244 x 113 x 52 mm (L x W x H)
Weight	1.7 kg
Relay outputs	Max 1 A/30 VDC. volt free relay outputs.
IP code	IP20
Soundfiles	16 sec/file
Bluetooth	Bluetooth 4.0 BLE 2,4 GHz
Operating temperature	+5 C° – +40 C°
Air humidity	30% – 90% RH
Interface Boards	*SL6-GSM-BOARD: - Micro SIM, 15 x 12 x 0,76 mm - Supports 2G - Requires SW 3.40 or later *IF-BOARD-4G - Micro SIM, 15 x 12 x 0,76 mm - Supports 2G, 3G and 4G - Requires SW 4.45 or later

Technical Data Voice Unit

Power	Supply voltage: 12 VDC, current drain nominal 15 mA
Inputs	10-30 VDC, 5 mA, optically isolated
Pictogram outputs	Max 100 mA, 24 VDC, transistor outputs, open collector
IP code	COP: IP00 COP2, Surface- or flush mounted units: IP40 To reach safety level IP4X, suitable additional protection have to be installed onsite.
Max cable length	0,22 mm ² cable: 100 m 0,75 mm ² cable: 250 m
Operating temperature	+5 C° – +40 C°
Air humidity	30% – 90% RH

Description of the Bus System

The SL6+ uses a bus system for communication between the main unit (SL6+) and the voice units.

The bus consists of four wires, which transfers power, voice and data.

You can have one SL6+ main unit and up to six voice units connected to the same bus.

The system uses addresses to communicate with a selected voice unit. It is important that each unit have the address selector set to a unique address. Available addresses are 1 to 6.

The system is based on a two-way system according to EN 81-28.

System Overview

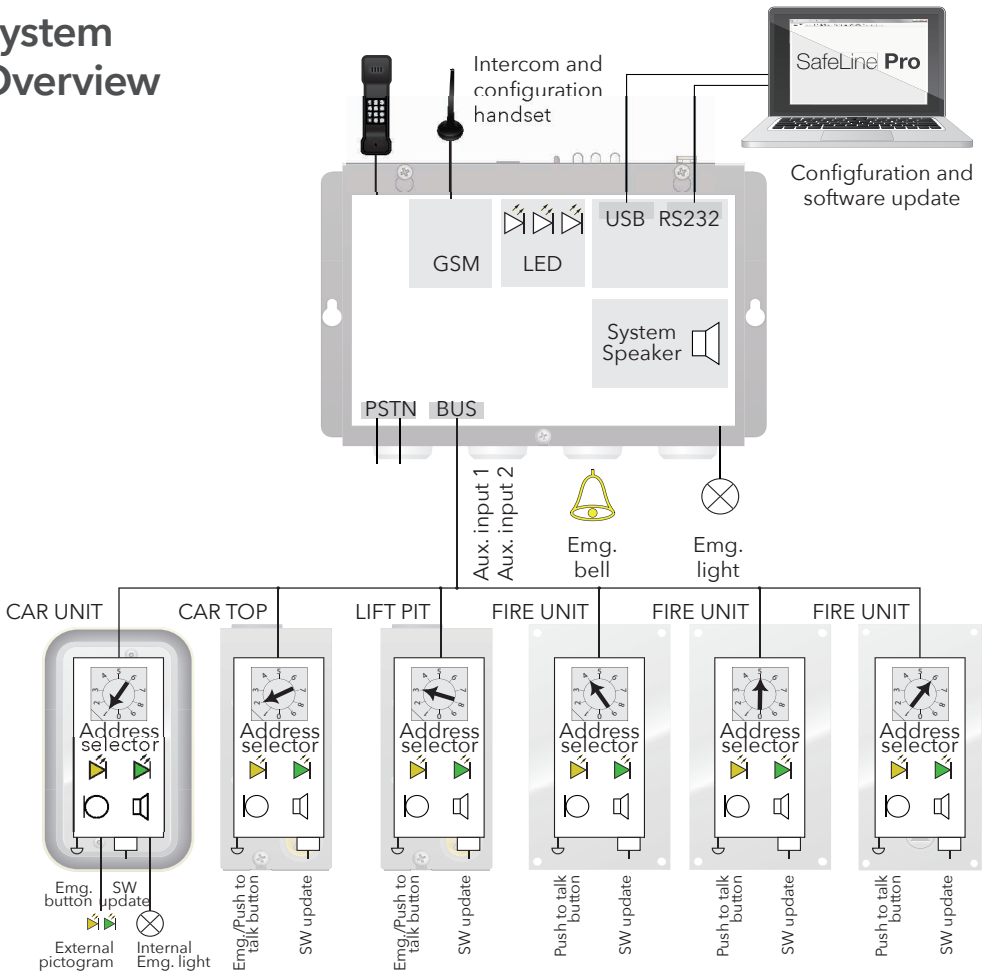

Overview SL6+ Main Unit

1. **Connector RJ12 for optional telephone handset**
For configuration and intercom communication. Can also be used for external calls. Any standard analogue tone dial telephone can be used.
2. **Resets button**
 - Reset all alarms.
 - Terminates a phone call in progress.
 - Triggers self test.
 - Activates display of GSM signal strength.
 - Triggers battery test.
3. **LED indicators**
 - a. Mains power
 - b. Active alarm/battery status
 - c. PSTN/GSM Net, call status
4. **USB Mini B PC connection**
For firmware update and configuration.
5. **RS232 PC connection**
For configuration.
6. **Screw terminal for optional telephone handset**
For configuration and intercom communication. Can also be used for external calls. Any standard analogue tone dial telephone can be used.
7. **Slot for optional card**
CANopen Lift (*SL6-CAN-BOARD)
8. **Connector for external system speaker**
9. **GND**
10. **Terminals**
11. **12 V Battery, 1,2 Ah**
12. **Slot for GSM interface board**
13. **Battery slot for RTC, Real Time Clock**
(not yet implemented)

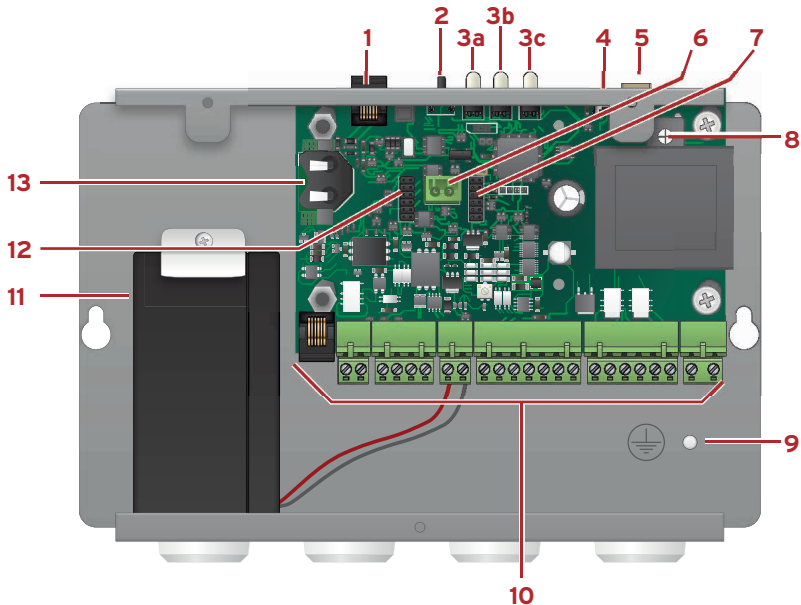

Overview SL6+ Voice Unit

If the default address settings needs to be changed it can be done in the main unit using SafeLine Pro

- 1. Local button***
Only N/O.
Is connected with *Cable13.
- 2. Screw connector terminals***
- 3. Emergency light***
Is connected with *Cable13.
- 4. Hearing loop***
Is connected with *Cable13.

**Note: This connection may not be present depending on the nature of your product.*

- 5. RS232 PC connection**
For firmware update.
- 6. Terminal RJ45**
Input/output, bus connection, power and external pictogram.
- 7. Address selector**
Selects the bus address for the unit.
- 8. Volume control**
- 9. Pictogram yellow**
- 10. Microphone**
- 11. Pictogram green**

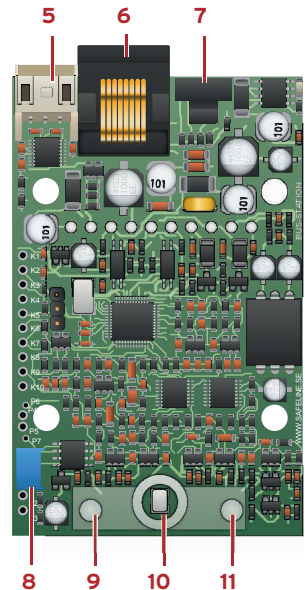
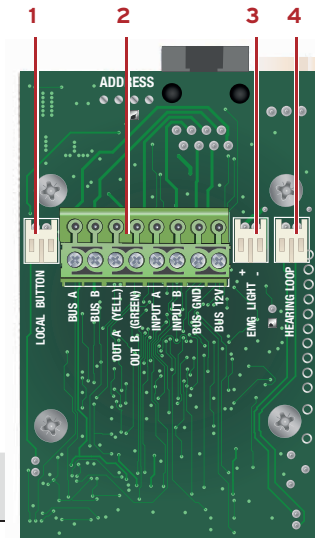

Default address setting:

Address	Unit
1	Car unit
2	Top unit
3	Lift pit unit
4	Fire unit
5	Fire unit
6	Fire unit

Overview SL6+ Voice Unit

1. Address selector
Fixed value set to 1 (car unit).
2. Connections
3. Pictogram output
4. Additional alarm button, N/O
5. RS232 PC connection
6. Volume control
7. Emergency light, only for SLB-SM-Pic-Light
8. Hearing loop

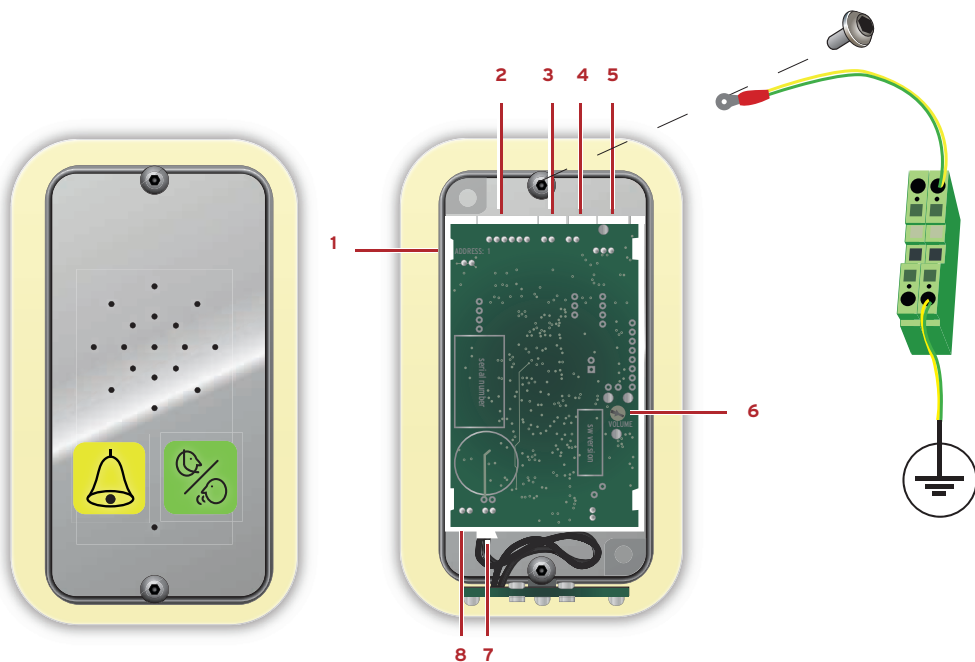

Other Components

1. GSM

Circuit board with GSM antenna connector, SMA: *SL6-GSM-BOARD or *IF-BOARD-4G (please refer to technical data, page 2, for detailed information).

2. SafeLine voice station for lift pit/car top

Mounted in the lift shaft, on top or under the car.

3. GSM antenna

4. SafeLine voice station for car

Equipped with a speaker and a microphone. Voice units available with pictograms to comply with EN 81-28. Also available with emergency alarm button and Rec Fire Key (key switch for fire intercom.)

5. SafeLine voice station with emergency light, for car

Equipped with a speaker, a microphone and a built in emergency light in the frame. Voice units available with pictograms to comply with EN 81-28.

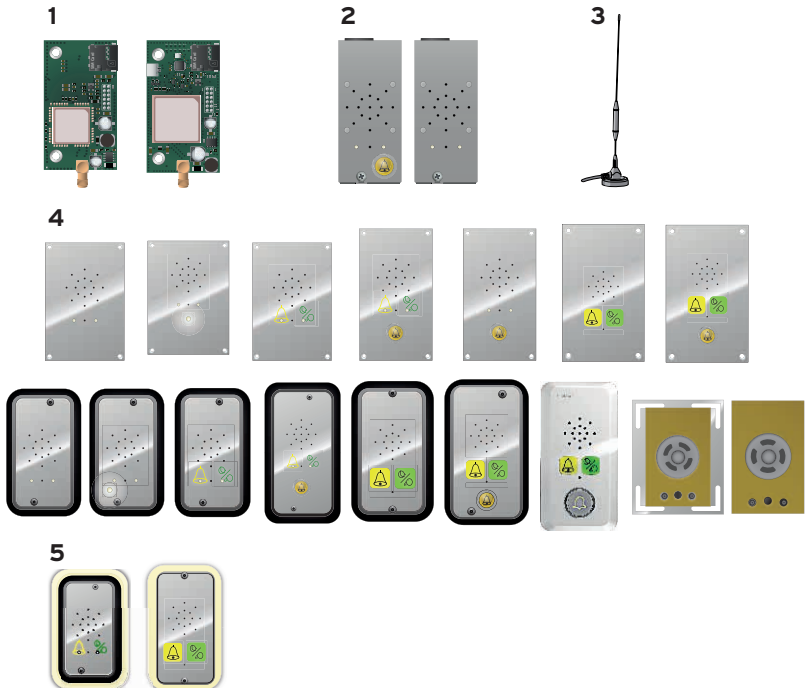

Mounting

If GSM interface is installed it has priority. If no active SIM card is used, GSM interface should be disabled.

Install the main unit in the machine room.
No termination resistance is needed at the ends of the bus.

To avoid GSM interference: Place the main unit, the stations and the GSM antenna at least 1,5 meters apart.



Mounting circuit board

Unplug the main power and battery before performing any changes.

Circuit boards that can be mounted are *SL6-GSM-BOARD or *IF-BOARD-4G (please refer to technical data, page 2, for detailed information).

*SL6-GSM-BOARD with Micro SIM Card

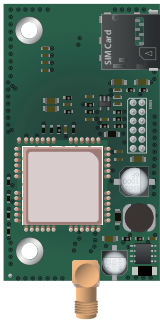

*IF-BOARD-4G with Micro SIM Card

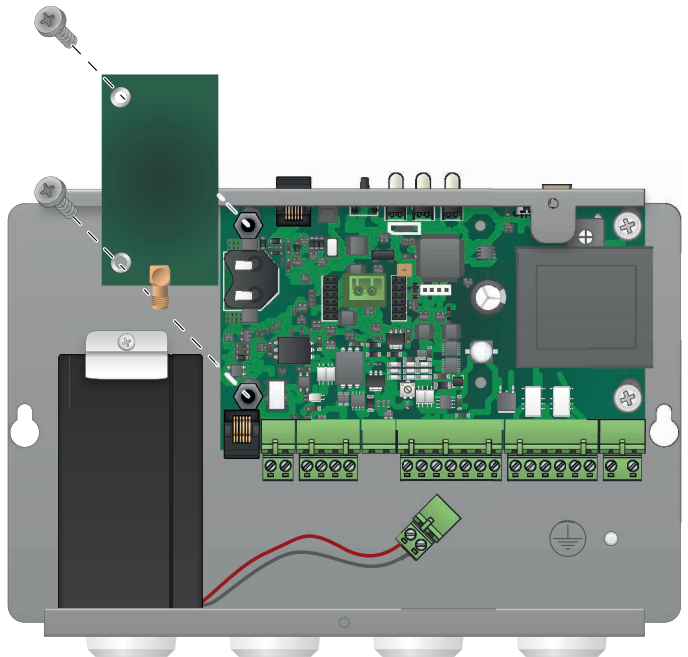
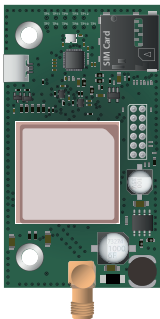

Wiring Diagram SL6+ Main Unit

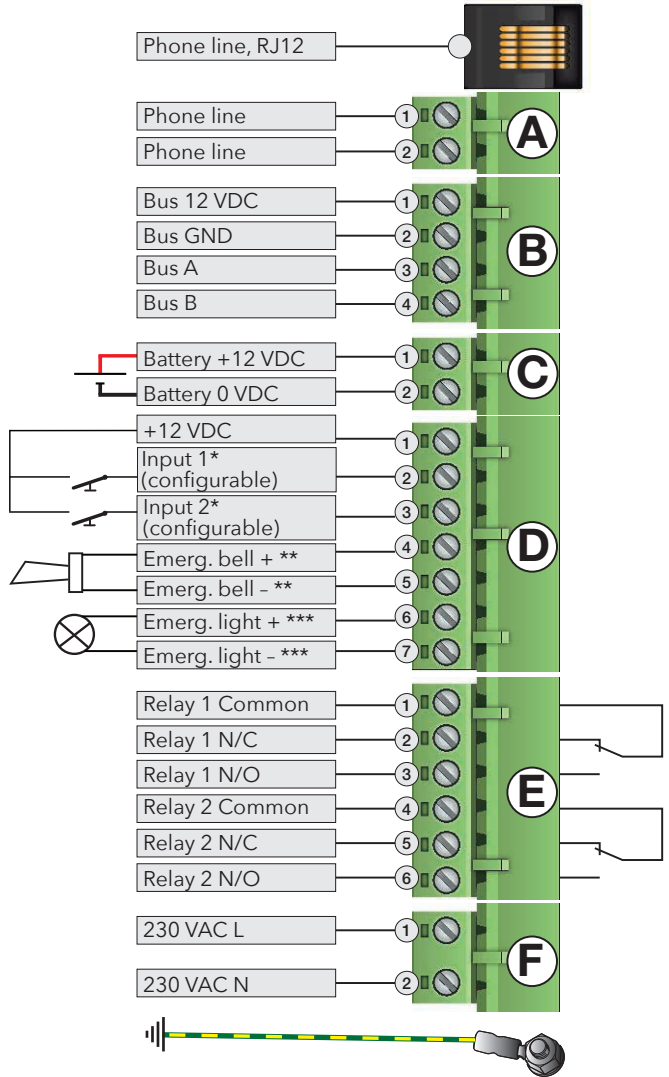

INPUT 1 AND 2 OPTIONS

NONE

FILTER

LMS/SMS

CLEAR/MAINTENANCE

FIRE MODE
(default input 2)

ALARM BUTTON
(default input 1)

CALL DELAY

* Input 1 and 2 are configurable N/O or N/C inputs with SafeLine Pro as indicated to the right.

** Maximum 200 mA on the emergency bell output.

*** Maximum 500 mA on the emergency light output.

Wiring Diagram Voice Unit

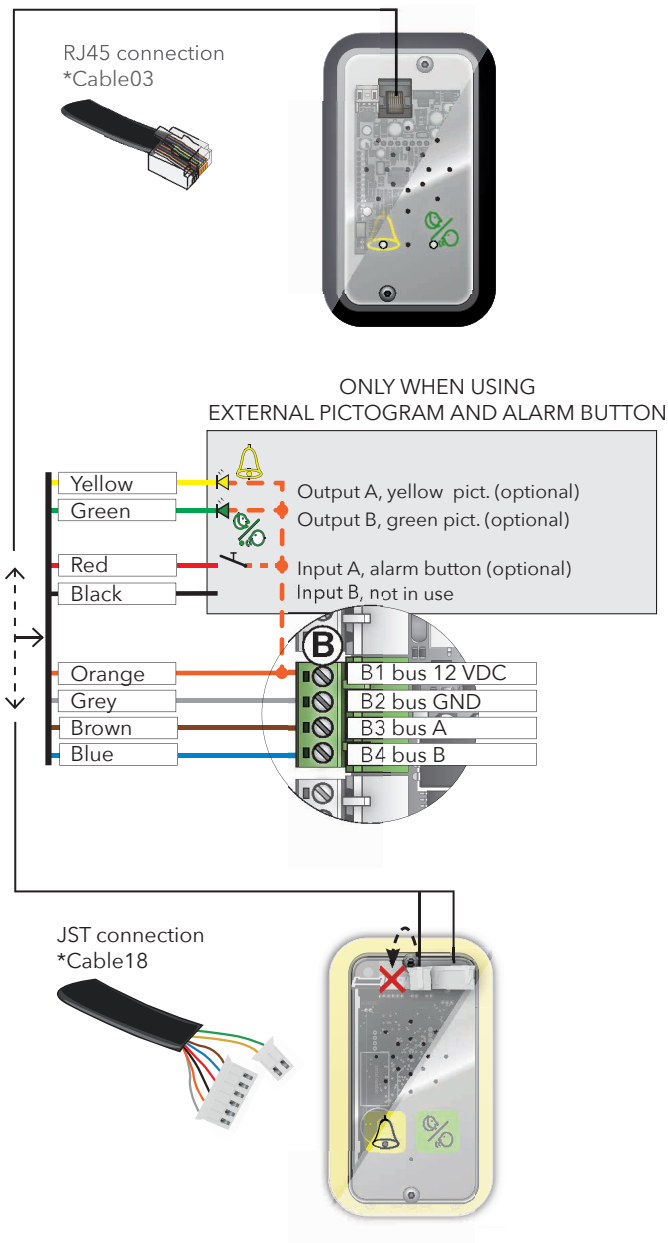

*Input A is configurable with either:

- SafeLine Pro N/O (default) or N/C.
- Parameter *89*, please refer to the corresponding code in the "Parameter List".

Wiring Diagram Voice Unit Screw Terminals

*Input A is configurable with either:

- SafeLine Pro N/O (default) or N/C.
- Parameter *89*, please refer to the corresponding code in the "Parameter List".

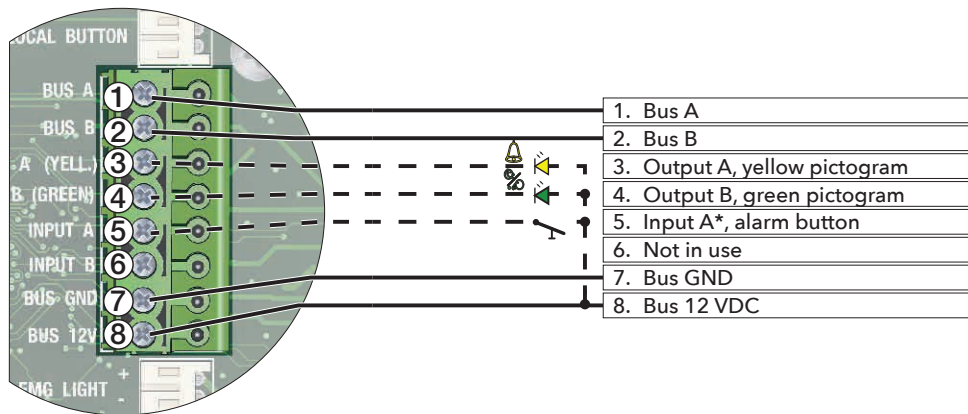

Connecting the Telephone Line

Connect the telephone line in parallel in universal terminals or the RJ-plug, see the picture above. It's possible to connect up to nine SL6+ main units to the same telephone line.

In order to access the unit remotely, it needs to be assigned a unit number. Please refer to parameter *82* in the "Parameter List" for more information.

Phone line is connected via RJ12 through the following:

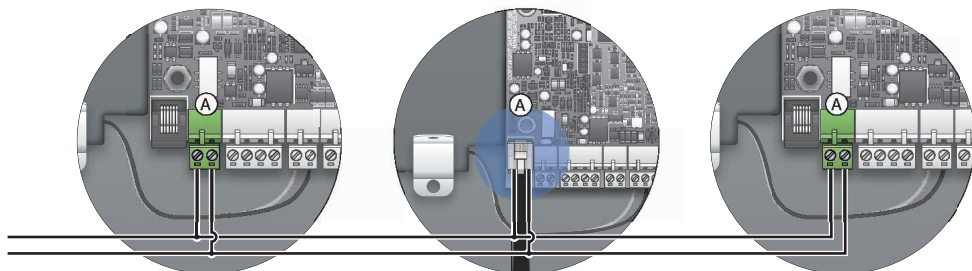
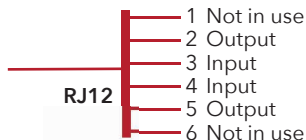

Activating the SIM Card

If you enter the wrong PIN code 3 times, the SIM card will be blocked (requires PUK code to unblock). The SL6+ can not be started and the LED3 will turn red.

The SL6+ can only recognise the PIN code if the code is set to "1234", "0000", "1111" or is deactivated. If the PIN code is set to "1234", "0000" or if it is deactivated, the SIM card can be moved from the SL6+ to any of SafeLine GSM products.

TIP: Do not activate the voice mail or, if possible, ask your provider to deactivate the voice mail.

If the PIN code is set to "1111" the SIM card code will be randomly changed by the SafeLine GSM unit and memorized. This way the SIM card can only work with the SafeLine GSM unit unless you use the PUK code for setting up a new PIN code.

If you want to upload a new SIM card with PIN code "1111" you will first need to upload a SIM card with PIN code "1234" or "0000" to clear the old code in memory.

Setting the PIN code

(Set to "1234", "0000" or deactivate.)

1. Insert the SIM card in an ordinary cellular phone. In the "Security settings" menu, change the PIN code to "1234". If this is not possible, set the PIN code to "0000" or set the "PIN code request" option to "OFF" (might not always function).
2. Verify the PIN code by switching your phone off and on again.
3. Make a call from your phone to verify that the SIM card is active before you move it to the SL6+.
4. Also make a call to SL6+ after insertion to check that it is possible to get a proper connection.

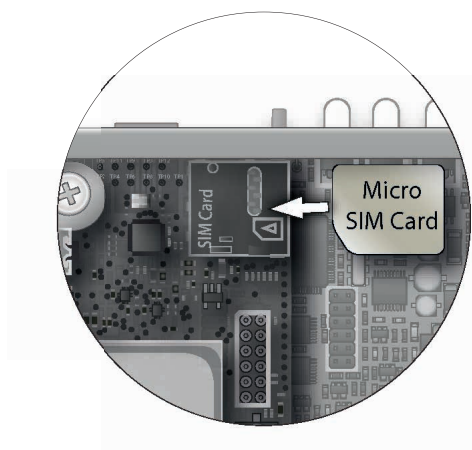

LED Indication Front Panel

LED 1 indicates the power supply status

Continuous green	Mains power supply OK
Flashing red (400/400 ms)	Battery operated, with power to the emergency light.
Continuous red	Battery operated, no power to the emergency light.

LED 2 indicates active alarm and battery condition

Light off	No active alarm/battery OK.
Rapidly flashing yellow (200/200 ms)	Active alarm not reset.
Flashing red (400/400 ms)	Battery check in progress.
Continuous red	Battery test failure/no battery connected.

LED 3 indicates the phone line's status

Flashing green (100/100 ms)	Fire mode activated.
Flashing green (400/400 ms)	Call connection in progress.
Slowly flashing green (200/4600 ms)	Telephone line connected.
Continuous green	GSM network OK.
Continuous green	Call connected.
Flashing yellow (100/100 ms)	Incoming call.
Flashing red (400/400 ms)	No telephone line connected.
	Searching for GSM network.
Continuous red	No SIM card (when using GSM).

Reset button

Press for 3 sec	Show GSM signal strength (see table below).
Press 3 times	Start a self test (battery + bus initialization).
Press once	Resets an active alarm. Aborts calls in progress.
Press 5 sec - release	SL6+ turns off. NOTE! Refers to battery powered only!

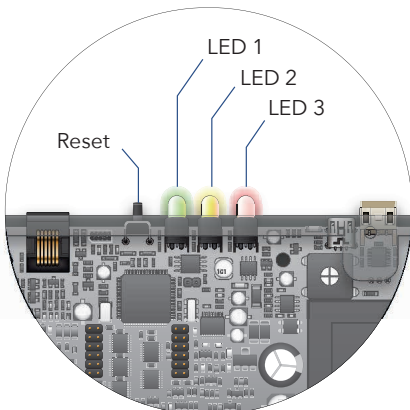

COLOUR CODE	LED			GSM SIGNAL STRENGTH
	1	2	3	
3 green				= 100 %
1 yellow, 2 green				= 85 %
2 yellow, 1 green				= 70 %
3 yellow				= 55 %
1 red, 2 yellow*				= 30 %
2 red, 1 yellow				= 15 %
3 red				= 0 %

*Minimum signal strength for using GSM interface.

LED Indication for Pictogram in Car

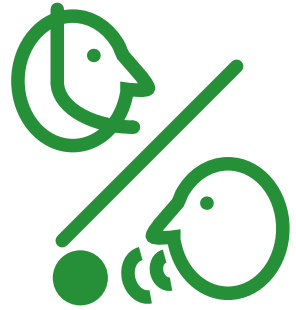
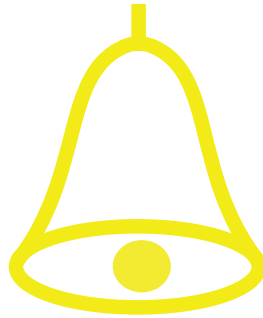

Yellow LED

Call in progress

The yellow pictogram LED, is lit as soon as the alarm button is pressed.

Green LED

Call connected

The green pictogram LED turns on as soon as the SafeLine unit detects a responding voice. The LED is turned off when the call is terminated.

Standard (*78*0#)

Light off

Yellow LED

No alarm activated

Green LED

Telephone line *not* OK.

Flashing slowly

Flashing once every 5 seconds
Telephone line *not* OK.

Flashing once every 5 seconds
Unit is OK.

Flashing quickly

Flashing twice every second
Alarm button active.

Flashing two times every 5 seconds
Alarm filter activated.

Continuous light

Activated alarm. Remains lit until reset.

Call connected.

Strictly EN81-28 (*78*1#)

Flashing

Yellow LED

Flashing twice every second
Alarm button active.

Green LED

Continuous light

Activated alarm. Remains lit until reset.

Call connected.

Startup Procedure

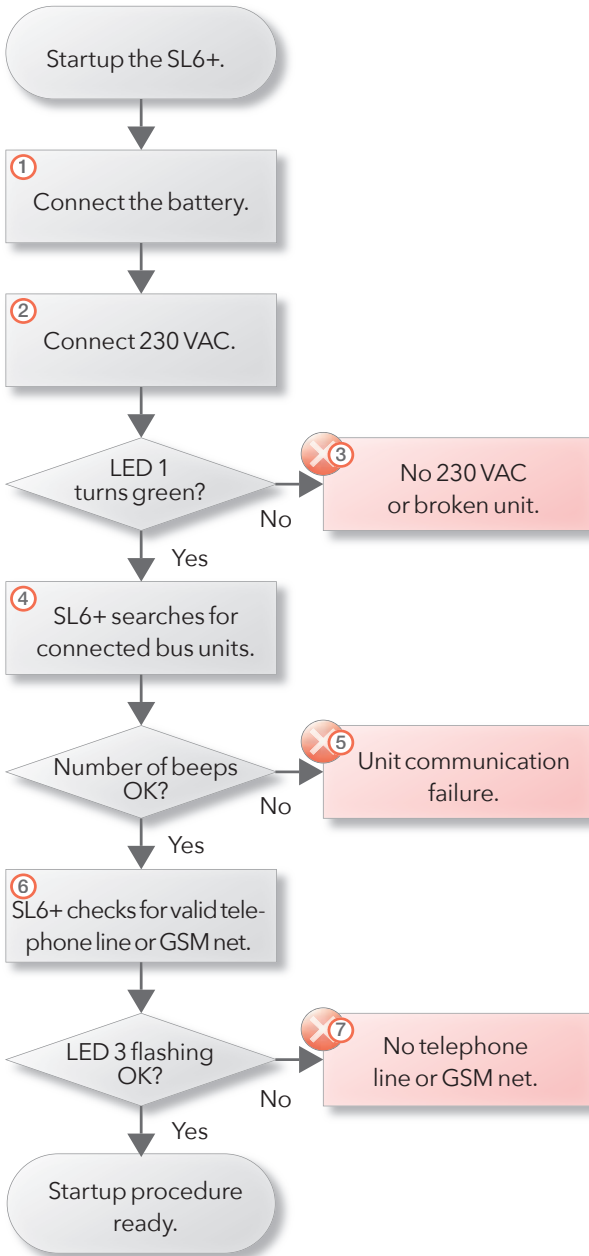

① The unit will not start at battery connection only.

② A tone sequence is heard in the system speaker at startup.

③ Check 230 VAC mains power.

④ SL6+ main unit searches for units connected to the bus. For every voice unit found, a beep sound is heard in the system speaker in the SL6+ main unit.



Example:
Found all voice units except for number 3.

⑤ Refer to chapter: Trouble shooting Voice unit.

⑥ When a valid telephone line is connected, or a GSM net is available LED3 is flashing green every 5 seconds.

⑦ Refer to chapter: Trouble shooting Main unit.

CONNECT

If the unit has been operational for more than 10 minutes when trying to connect, it will ask for a password.
If that is the case: please turn the unit off and on again, then try to reconnect.

CONNECT is the tool from SafeLine that will make configuration of SafeLine products easier than ever before. Configuration is done wirelessly with compatible products and the SafeLine CONNECT smartphone app, which is available free of charge on the Apple App Store and on Google Play.

Easy to learn and use

The app has an intuitive interface for configuration and changes of settings. Simply follow the instructional steps in the app to configure the SafeLine unit. There is no longer any need to use a computer or to remember a long list of configuration codes in order to configure SafeLine products. CONNECT functions includes templates which will allow pre-configured settings.

CONNECT is secure

CONNECT is protected against unauthorised use and all SafeLine products with built-in CONNECT functionality are password protected.

Always accessible

With the built-in CONNECT functionality, configuration is always accessible. All that is needed is a smartphone or tablet with the free app installed - no computer needed for configuration or changes in settings.



App Store, iPhone



Google play, Android

Configuration with PC

Configuration with SafeLine Pro.

The unit can be configured at the office prior to the installation or on site after installation. The configuration software SafeLine Pro can be downloaded from www.safeline-group.com. The configuration cable is provided by SafeLine.

If SafeLine Pro is used for configuration, you can go directly to chapter "Operating".



Remote configuration with SafeLine Pro/ProLink.

The unit can also be remotely configured at the office after installation. Connect a SafeLine ProLink modem with a phone line to a computer with SafeLine Pro and a serial cable.



Configuration with Telephone

Configuration methods with telephone and configuration codes are described in "Remote configuration with telephone" and "On-site configuration with telephone".

On site configuration with telephone

For configuration, you can use any PSTN tone dial phone.

- Plug the handset into the RJ12-contact of the main station.
- Enter configuration codes on the handset keypad.



Remote configuration with telephone

For remote configuration, you can use any PSTN tone dial phone.

- Dial the phone number of the SL6+.
- Enter the function codes on the phone keypad to start configuration (password has to be entered).

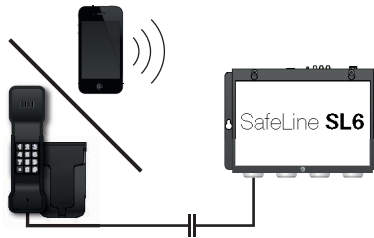

Remote Configuration with Telephone: First Step

In order to remotely configure the SL6+, the unit must first be put into configuration mode via voice communication mode. To enter voice communication mode, refer to the instructions below.

After the unit has been set in voice communication mode, follow the steps for remote configuration on the next page.

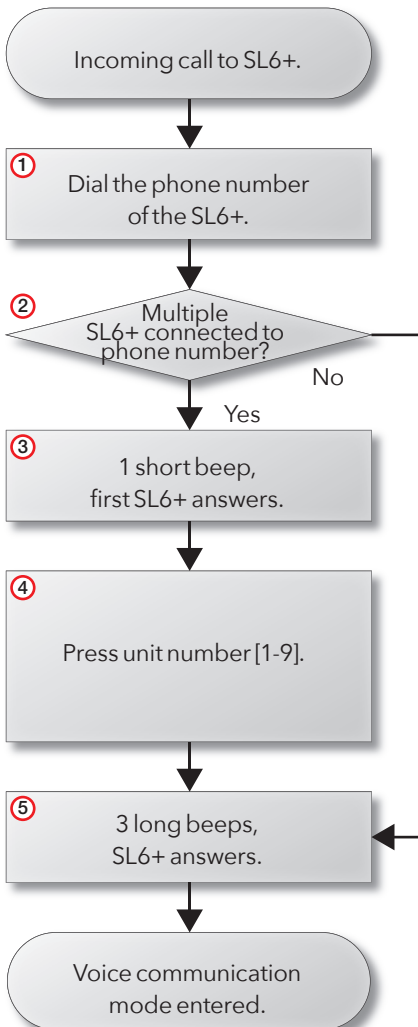

- ① Dial the phone number of the unit's phone.
- ② If there is only one unit connected, the unit answers with 3 long tones. If there are multiple units connected, the unit answers with a short beep. If there are more than one unit connected to the phone number, use the unit number to communicate with the selected unit.
- ③ After 2 rings the unit answers with a short beep.
- ④ If there are two or more SL6+ units connected in parallel you have to press the unit number just once. If there are other units (e.g SafeLine 3000, MX2) connected in serial you may have to press the unit number several times before the 3 long tones are heard.
- ⑤ When 3 long tones are heard, the selected unit is reached and voice communication mode is established. Now the telephone beeps every 5 seconds. This is to notify the passengers of the ongoing call (anti eavesdropping).

Remote Configuration with Telephone: Second Step

If the time between the operation of two keys exceeds 10 seconds, the code has to be re-entered.

If the time exceeds 30 seconds, the call is disconnected or configuration mode is ended.

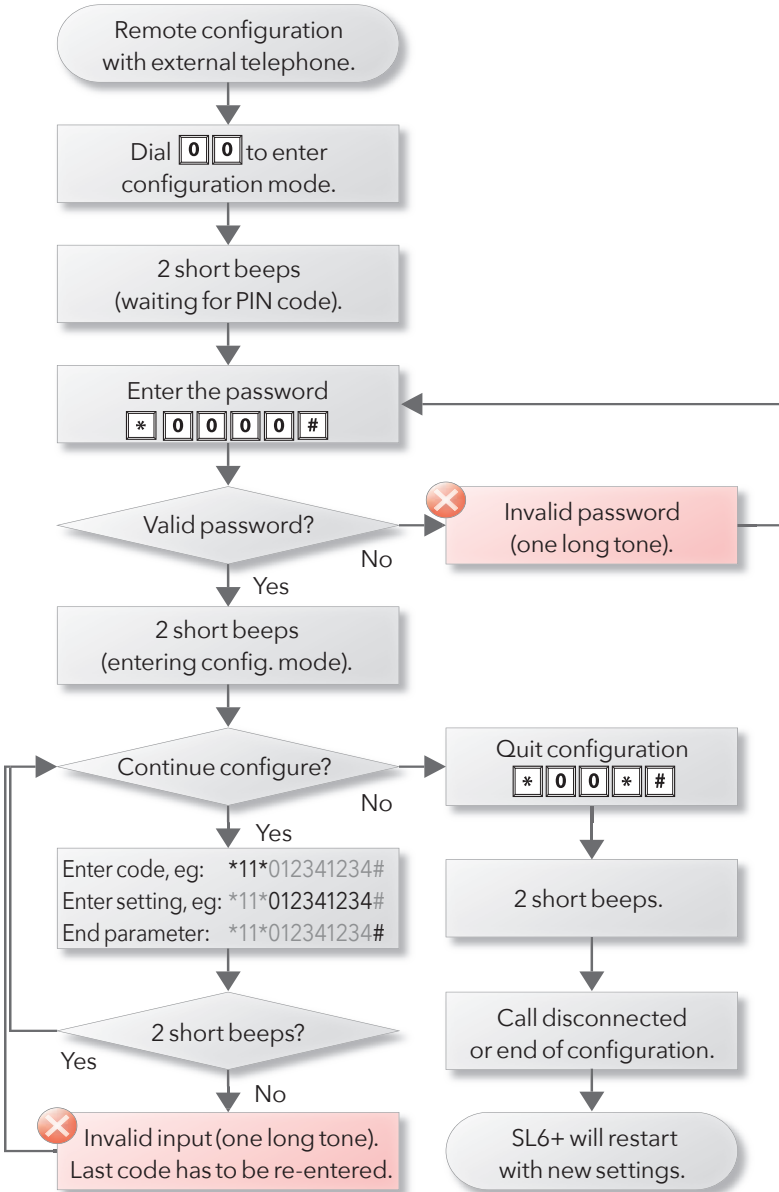

On-Site Configuration with Telephone

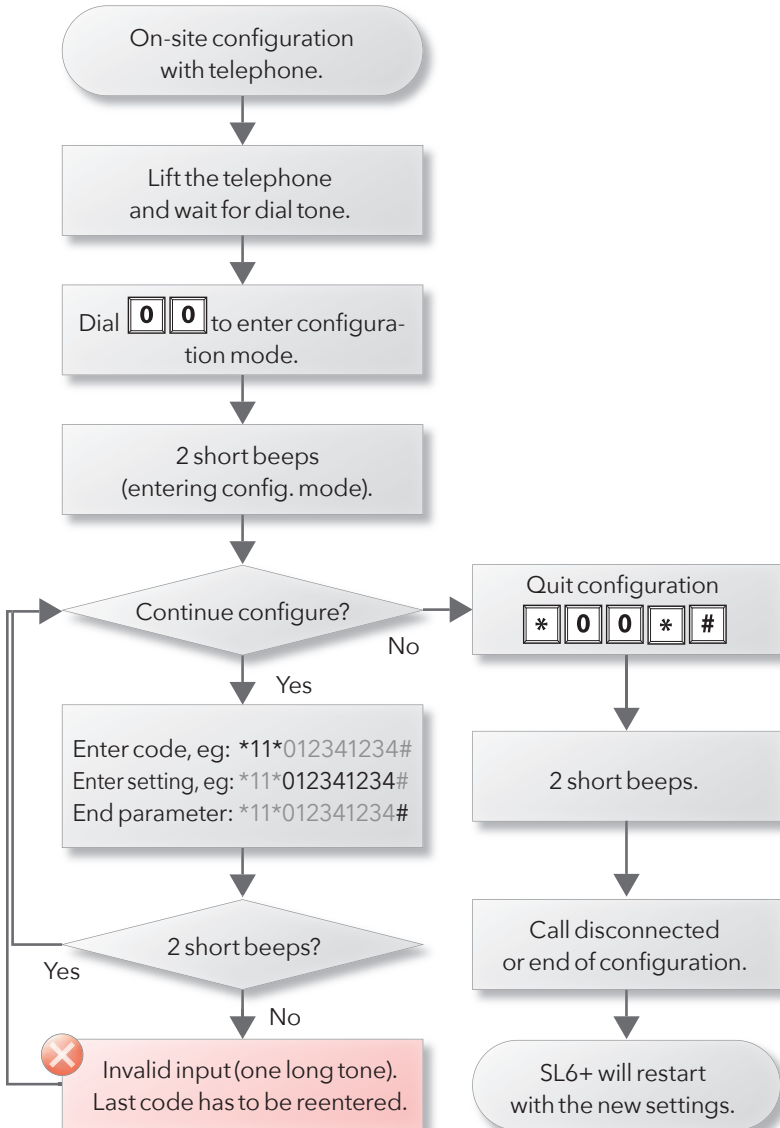

Configuration Examples

If at any time you need to start over, use the factory reset command *99*1#.

Please refer to the full configuration setup in the "Parameter list" as these are merely examples.

SafeLine emergency telephone Units

Example 1.

Storing of two different telephone numbers, one to be answered by P100 code and the other one with voice. (For test facility, see example 2.)

1. Start configuration:

0	0
---	---
2. 1st phone number:

*	1	1	*	1	2	3	4	5	6	7	8	#
---	---	---	---	---	---	---	---	---	---	---	---	---
3. 2nd phone number:

*	1	2	*	2	3	4	5	6	7	8	9	#
---	---	---	---	---	---	---	---	---	---	---	---	---
4. Call type 1st number:

*	2	1	*	0	#
---	---	---	---	---	---

 - Example: Answered with P100 code.
5. Call type 2st number:

*	2	2	*	1	#
---	---	---	---	---	---

 - Example: Answered as voice call.
6. Alarm button delay:

*	8	7	*	0	3	#
---	---	---	---	---	---	---

 - Example: 3 seconds delay.
7. End configuration:

*	0	0	*	#
---	---	---	---	---

Example 2.

SLCC (SafeLine Call Centre) and 3 day test.

1. Start configuration:

0	0
---	---
2. Enter P100 ID code:

*	0	1	*	4	5	6	4	5	6	4	5	#
---	---	---	---	---	---	---	---	---	---	---	---	---

Lift ID code (each lift must have its own unique code).
3. Set test alarm type:

*	3	1	*	0	#
---	---	---	---	---	---

 - Example: Test alarm type P100.
4. Set number of days between test alarm:

*	2	7	*	0	3	#
---	---	---	---	---	---	---

 - Example: 3 days between test alarm.
5. LMS phone number:

*	1	6	*	9	8	7	6	5	4	3	2	#
---	---	---	---	---	---	---	---	---	---	---	---	---

(Only if using SLCC)
6. Test alarm:

*	1	7	*	1	2	3	1	2	3	1	2	#
---	---	---	---	---	---	---	---	---	---	---	---	---

(For more information, please refer to parameter *17* in the "Parameter list")
7. End configuration:

*	0	0	*	#
---	---	---	---	---

Parameter List

CONFIGURATION DATA	CODE	DATA	COMMENTS
Enter configuration mode		00	
Enter password		* --- #	Default = 0000
Exit configuration mode		*00*#	
ALARM CODES	CODE	DATA	COMMENTS
P100 ID code	*01*	-----#	P100 is always 8 digits
CPC ID code	*02*	-----#	CPC 6-8 digits
Q23 ID code	*03*	-----#	Q23 is always 12 digits
TELEPHONE NUMBERS	CODE	DATA	COMMENTS
1st Phone number	*11*	-----#	Phone number to alarm receiver: 1-20 digits. If calling through a switch board, delay time can be set by adding asterisks between leading number of the switch-board and telephone number for the alarm call receiver. Each asterisk (*) is equal to one second delay. Example #1: *11*0**1234567# Example #2: *11*# deletes the phone no.
2nd Phone number	*12*	-----#	
3rd Phone number	*13*	-----#	
4th Phone number	*14*	-----#	
CALL TYPE	CODE	DATA	COMMENTS
Call type 1st number	*21*	- #	Change the call type of the stored telephone numbers: 0 = P100 1 = VOICE (default) 2 = Q23 3 = CPC Change this only if your alarm operator uses any of the mentioned protocols.
Call type 2nd number	*22*	- #	
Call type 3rd number	*23*	- #	
Call type 4th number	*24*	- #	
Call type LMS number	*30*	- #	LMS (Lift Monitoring System) call type 0 = P100 3 = CPC (Only battery alarm) 5 = SMS

**TEST ALARM
BATTERY ALARM****CODE DATA****COMMENTS**

LMS phone number	*16* -----#	LMS (Lift Monitoring System) phone number to alarm receiver or SLCC.
Test alarm	*17* -----#	Phone number to send testalarm to alarm receiver or SLCC.
Call back test alarm	*19* -----#	Triggers a test alarm event to a user selected phone number. The call is made after the configuration is terminated.
Days between tests	*27* --#	Number of days between test alarms, 00-99 days. Always two digits. Max 3 days according to EN 81-28. 00 = No test alarms
Test alarm protocol	*31* -#	0 = P100 3 = CPC 4 = Caller ID

ALARM TYPE**CODE DATA****COMMENTS**

Alarm type 1st number	*41* --#	Only when using CPC as alarm protocol Normally 10 or 27, check with your alarm company!
Alarm type 2nd number	*42* --#	
Alarm type 3rd number	*43* --#	
Alarm type 4th number	*44* --#	
Alarm type LMS	*45* --#	LMS (Lift Monitoring System) (Battery alarm) Normally 17
Alarm type Test alarm	*46* --#	Normally 26

DISTRESS MESSAGE	CODE	DATA	COMMENTS
Record distress message played in the lift car.	*50*	"Speak" #	This message will be played in the lift car when the emergency lift telephone starts calling the alarm centre. Make sure that there is no noise in the background when recording the message. Example of message: Please do not panic, the emergency telephone is now calling the emergency call centre.
Record alarm message from bus unit 1 to alarm central	*51*	"Speak" #	This message will be played to the alarm receiver and in the car when the call is answered. Make sure that there is no noise in the background when recording the message.
Record alarm message from bus unit 2 to alarm central	*52*	"Speak" #	
Record alarm message from bus unit 3 to alarm central	*53*	"Speak" #	Example of message: This is an alarm from the lift on 5th avenue.
Record alarm message from bus unit 4 to alarm central	*54*	"Speak" #	
Record alarm message from bus unit 5 to alarm central	*55*	"Speak" #	To hear the message again, and listen to the quality of the message, press "1".
Record alarm message from bus unit 6 to alarm central	*56*	"Speak" #	
Record fire message	*57*	"Speak" #	To terminate the call press "#".
Options for the recorded distress message	*60*	-#	To play the recorded message, press the desired parameter followed by #. For example: *61*# in order to play the message from the bus unit.
	60	#	
Options for the recorded message from bus unit 1	*61*	-#	0 = Disable recorded message. 1 = Enables recorded message.
	61	#	
Options for the recorded message from bus unit 2	*62*	-#	
	62	#	
Options for the recorded message from bus unit 3	*63*	-#	
	63	#	
Options for the recorded message from bus unit 4	*64*	-#	
	64	#	
Options for the recorded message from bus unit 5	*65*	-#	
	65	#	
Options for the recorded message from bus unit 6	*66*	-#	
	66	#	
Options for the recorded fire message	*67*	-#	
	67	#	

OTHER CODES	CODE	DATA	COMMENTS
2G/3G/4G	*07*	-#	0 = 2G + 3G + 4G (default) 1 = 2G + 3G 2 = 2G + 4G 3 = 3G + 4G 4 = 2G 5 = 3G 6 = 4G
Modem functions	*09*	-#	0 = USB 1 = Series (RS232)
Repeated alarm	*39*	-#	Repeated alarms: Battery failure, Mic/ Speaker failure, Stuck button. Alarm action repeats every 24h until the problem is resolved. 0 = Off (default) 1 = On
Buzzer	*71*	- #	The buzzer will sound at incoming call or at intercom use. 0 = Off 1 = On (default)
Ring-tone timeout	*72*	-- #	Number of ring signals before dialling the next number (default = 08).
External inputs - Function	*73*	-- #	The first number selects the input, i.e. Input 1 or Input 2. The second number selects the function. 0 = None 1 = Filter 2 = LMS/SMS 3 = Clear/Maintenance 4 = Fire Mode 5 = Alarm Button 6 = Call Delay Example: *73*11# - Input 1, Filter *73*26# - Input 2, Call Delay
External inputs - Input N/O or N/C	*74*	-- #	The first number selects the input, i.e. Input 1 or Input 2. The second number selects N/O (0) or N/C (1). Example: *74*11# - Input 1, N/C *74*20# - Input 2, N/O
Hotline	*75*	- #	Phone connects directly to a fixed receptient without phone number. 0 = Standard phone line (default) 1 = Hotline

OTHER CODES	CODE	DATA	COMMENTS
Compatibility mode	*77*	- #	<p>0 = Automatic voice switching (default) The call is validated when there is a voice response. The call is terminated by pressing "#".</p> <p>1 = Kone ECII (lift telephone) When there is a voice response, some ascending tones will be heard. The call is validated by pressing "4". The call is terminated by pressing "0". The call is terminated without receipt notification by pressing "2"(the unit will call the next number).</p> <p>2 = Manual voice switching When there is a voice response, some ascending tones will be heard. The call is validated by pressing "4". Unit is still in automatic mode. To enter manual mode and talk press "*". To listen press "7". Go back to automatic mode press "4". The call is terminated by pressing "#". It is possible to enter manual voice switching mode although the unit is programmed as automatic by pressing "*". No ascending tones will be heard. For repeating the Alarm messages to operator, press "1" in all in/out going calls.</p> <p>3 = Swiss Mode (Alarm operator mode) Only to be used in voice mode. Disconnect by "0". Dials the next number if call timeout, blocking tone, new dialing tone, and operator silence.</p>
Indicator mode	*78*	- #	<p>0 = Standard (default) 1 = Strictly EN81-28</p>
Maximum communication time Incoming/Outcoming calls	*79*	- #	<p>1 - 5 minutes. (Default: VOICE = 5 min, other protocols = 8 min)</p>
Reset active alarm	*80*	- #	<p>0 = Off 1 = On (default)</p>
Auto answer	*81*	- - #	<p>Number of signals before SafeLine answers incoming call. Can be set from 00-16 (default = 02). 00 = Never answering.</p>
Unit number	*82*	- #	<p>Unit number [0] is set by default, and means that the unit will respond immediately.</p> <p>Unit number [1-9] is used when the units are sharing the same phone line. When the unit number is assigned, the specified unit is accessible for configuration.</p>
Detect dial tone	*83*	- #	<p>0 = Off 1 = On (default)</p> <p>Set to off if SafeLine has problem to detect the dial tone.</p>

OTHER CODES	CODE	DATA	COMMENTS
Receipt to alarm receiver	*84*	- #	Select which message(s) to send to the alarm receiver at an alarm call. 0 = None (default) 1 = Start of alarm 2 = Start+end of alarm
Break on new alarm	*86*	- #	Disconnects a call longer than 60 sec. at new activation of the alarm button and calls the next emergency call number. 0 = Off 1 = On (default)
Alarm button delay time	*87*	-- #	Delay time from pressing the alarm button until activating the alarm. 00-25 seconds. Default = 05
Outputs	*88*	-- #	The first number selects the relay output, i.e. Relay 1 or Relay 2. The second number selects the function. For SW 4.00 or later, the following parameters are used: 0 = Alarm status outputs (default relay 1) 1 = Battery failure (default relay 2) 2 = Pictogram (Relay 1 - yellow, relay 2 - green) 3 = Activate with DTMF 8/9 (relay 1 - DTMF 8, relay 2 - DTMF 9) 4 = Manual reset 5 = Emergency call failure 6 = System failure 7 = Emergency bell Example: *88*11# - Relay 1, battery failure *88*26# - Relay 2, system failure For more information, please refer to "Relay Functions" (page 33) For SW previous to 4.00, the following parameters are used: 0 = Standard (default) 1 = EN81-28 Pictograms 2 = DTMF-controlled 3 = Manual - ECF (Emergency Call Fail) For more information about the parameters in the older versions, please contact the support team.
Bus unit - Alarm input	*89*	-- #	Selected alarm input type for the bus unit (N/O or N/C). First number selects the bus unit (1-6). Second unit selects N/O (0) or N/C (1). Example: *89*21# sets bus unit 2 as N/C

OTHER CODES	CODE	DATA	COMMENTS
Voice unit - Integrated emergency bell	*90*	--#	Local configuration of emergency bell voice unit. First number selects voice unit (1-6). Second number selects Off (0) or On (1). Example: *90*21# sets voice unit 2 to On
Change password	*91*	---#	Change password (default=0000).
Operator silence disconnect	*92*	-#	Disconnects the call when the alarm operator has been quiet for longer than the time set. 0 = Off (default) 1 = 30 sec 2 = 60 sec 3 = 90 sec
Fallback	*93*	-#	0 = Disabled (default) 1 = Priority PSTN 2 = Priority GSM
Simulate an alarm event	*94*	-#	Triggers an alarm event after configuration is terminated. 1 = Emergency call 2 = Test alarm 3 = Battery failure 4 = Microphone/speaker failure 5 = Receipt on voice call 6 = Maintenance 7 = Main unit power failure 8 = Stuck button alarm
GSM/PSTN - RX audio level	*96*	-#	Increases the received audio level. Is used only if the audio level from the alarm central is too low. 0 = 0% (default) 1 = +25% 2 = +50% 3 = +75% 4 = +100% Note. SW 4.4 0 or later is required. For PSTN, HW 1.41 or later is required.
Background level compensation	*97*	-#	0 = Off 1 = On (default)
Reset to default settings	*99*	-#	1 = Factory standard 2 = Default P100 (The following codes will be set): *21*0#, *22*0#, *27*03#, *80*1#, *84*1#, *88*1# 3 = Default CPC (The following codes will be set): *21*3#, *22*3#, *27*03#, *80*1#, *84*1#, *88*1# 4 = Default VOICE (The following codes will be set): *21*1#, *22*1#, *27*03#, *80*1#, *84*1#, *88*1#

Relay Functions

This applies for SW 4.00 or later. (Functions for earlier versions, please contact the support team.)

Relays 1 and 2 can be programmed independently.

Alarm status outputs

- Relay will be activated when set time reached.
- Relay will be deactivated when emergency call ends.

Battery failure

- Relay will be activated when the battery test has failed.
- Relay will be deactivated by pressing the reset button.

Pictogram yellow (only relay 1)

- Relay will be activated when the alarm button is pressed (yellow pictogram).
- Relay will be deactivated when the reset button is pressed or if alarm centre presses "5".

Pictogram green (only relay 2)

- Relay will be activated when the call is acknowledged (green pictogram).
- Relay will be deactivated when the call is disconnected.

Activate with DTMF 8 (only relay 1)

- Relay will be activated for 5 seconds when DTMF "8" is pressed.

Activate with DTMF 9 (only relay 2)

- Relay will be activated for 5 seconds when DTMF "9" is pressed.

Manual reset

- Relay will be activated when set time reached.

Emergency call failure

- Relay will be activated when the emergency call failed after 12 attempts, "Emergency Call Fail".

System failure

- Relay will be activated when power (230 VAC) and PSTN/ GSM net is OK.
- Relay will be deactivated when power supply is gone more than 15 min or when there is no GSM-net.

Emergency bell

- Relay will be activated when the emergency bell input is active.
- Relay will be deactivated when the emergency bell input is deactivated.

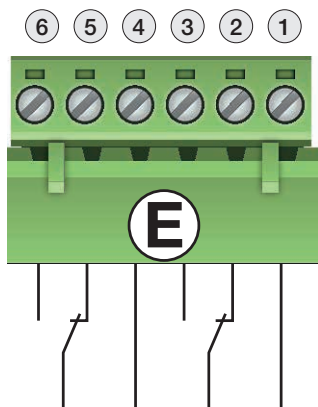

Calling with SafeLine SL6+

Installing the handset and the SL6+ in the machine room is recommended.

The handset can not be called from the car unit.

The SafeLine SL6+ can call in the following ways:

1. Intercom between machine room and car/pit/car-top, see below.
2. Making calls like with a normal fixed line phone (also GSM).
3. Emergency calls to numbers at the press of the alarm button.
4. Test alarms at preset intervals.
5. Send receipts to SLCC alarm receiver for defined conditions.
6. Send SMS to one or several GSM phones at defined conditions (GSM only).
7. Provoke test calls.

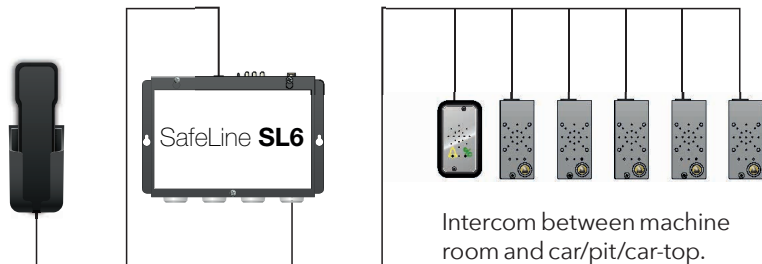

Intercom between machine room and car/pit/car-top.

Intercom between Main Station and Voice Unit

Main station to voice unit

Press 1-6 on the handset to call respective voice unit.

Voice unit to main station

Press the button on the voice station briefly to call the main station.

(Hold the button for 5 seconds to make an emergency call.)

Outgoing Call

Press 0 to dial external telephone number.

If the Safeline SL6+ is connected to a PABX (switchboard), press 0 again for external dial tone to calling out to the PSTN network.

If a GSM unit is installed, the SL6+ will use it as the default. If a PSTN-line is used, ensure that there is NO GSM unit installed.

Emergency Calling Process

Maximum 12 calls

With 4 stored telephone numbers, each number could be called 3 times. This adds up to the 12 call limit.

To restart the dialling process, another push of the alarm button is needed.

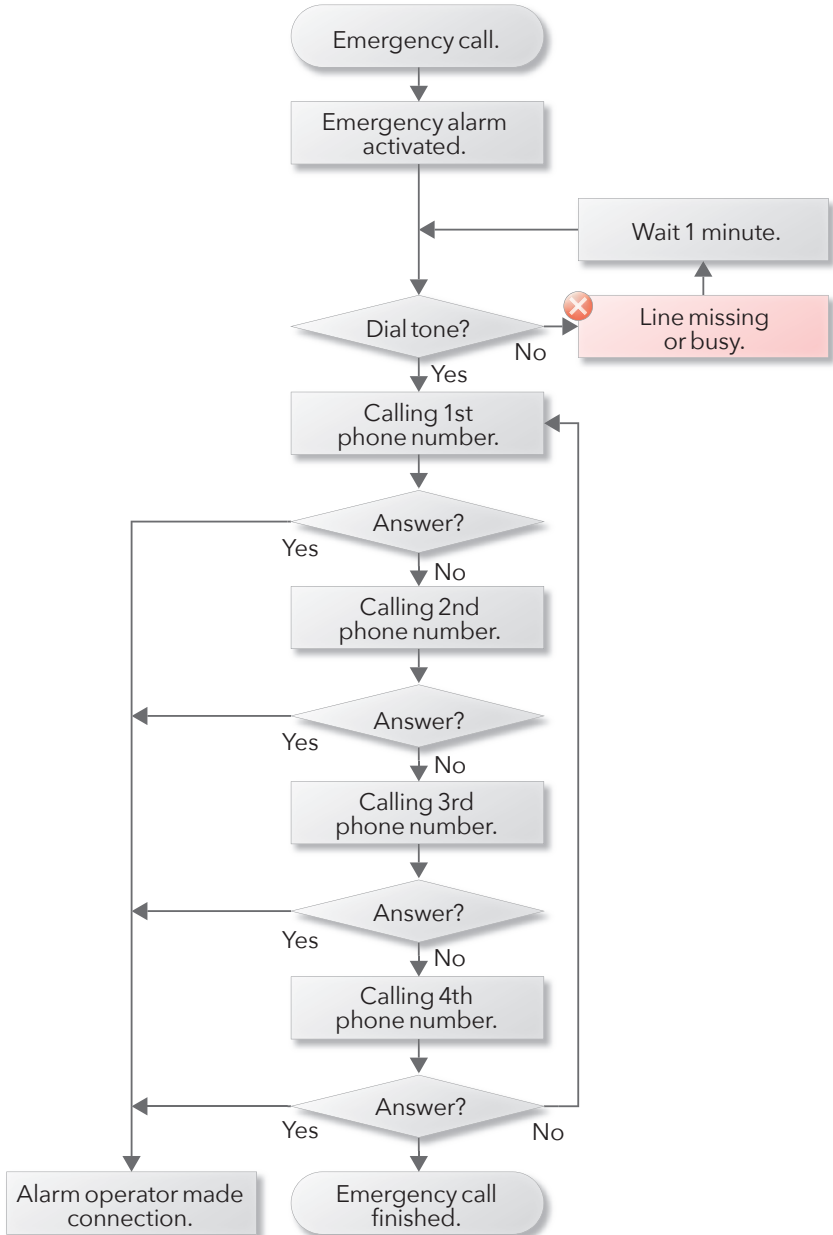

Incoming Call Process

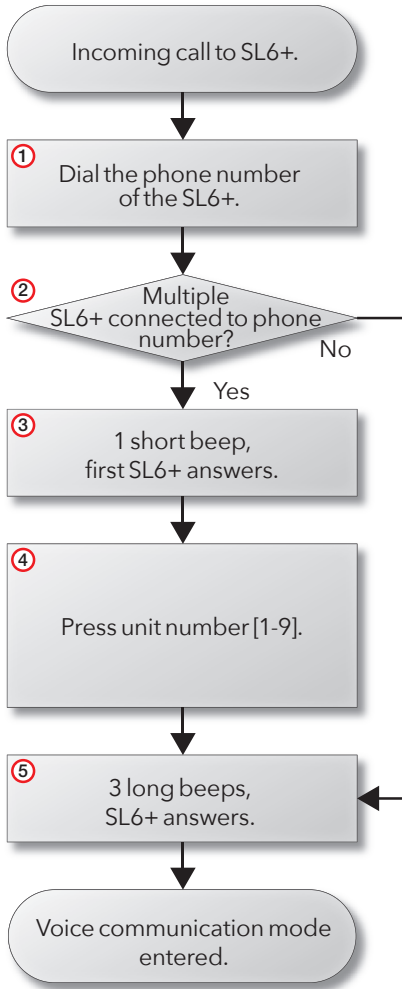

An incoming call is connected to the voic unit that initiated the most recent active emergency call.

This applies as long as the 'Reset active alarm' is switched off (please refer to parameter *80* in the "Parameter List" (page 26)).



- ① Dial the phone number of the unit's phone or GSM subscription.
- ② If there is only one unit connected, the unit answers with 3 long tones. If there are multiple units connected, the unit answers with a short beep. In that case, use the unit number to communicate with the selected unit.
- ③ After 2 rings the unit answers with a short beep.
- ④ If there are one or more SL6+ units connected parallel, you have to press the unit number just once. If there are other units (e.g. SafeLine 3000, MX2) connected in serial, you may have to press the unit number several times before the 3 long tones are heard.
- ⑤ When 3 long tones are heard, the selected unit are reached and voice communication mode is established. Now the telephone beeps every 5 seconds. This is to notify the passengers of the ongoing call, anti eavesdropping.

Fallback

-  = 200 (0,2 sec)
-  = 400 (0,4 sec)
-  = 1000 (1 sec)

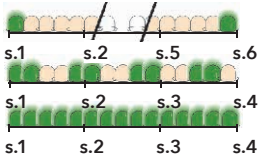
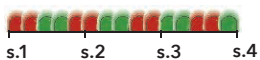
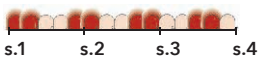
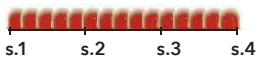
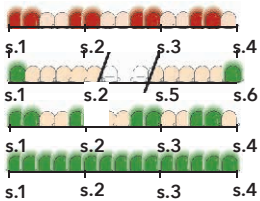
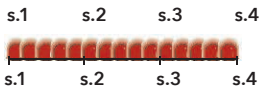
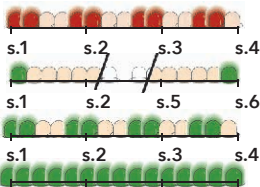

The Fallback function gives access to use both the PSTN and GSM for emergency calls. Set one as a preset and the other one works as fallback in case the preset were to fail (the function requires that both phone line and GSM SIM card are active).

Fallback can not be used to override a GSM unit installed, when missing SIM card. When activating Fallback, both systems have to be operative. Incoming calls are handled by both interfaces, but will not be used simultaneously.

The unit can be configured to send a text message with an interval of 1-99 days, in order to keep the SIM card active. The configuration can be made through SafeLine Pro.

For programming, use SafeLine Pro or parameter *93* (please refer to the corresponding code in the "Parameter List"). If no active SIM card is used, GSM interface should be disabled.

LED 3:

Fallback disabled - PSTN interface

Flashing Red, 400/400 ms: no line

Slowly flashing green, 200/4600 ms: line OK

Flashing green, 400/400 ms: connecting call

Continuous green: call connected

Fallback disabled - GSM interface

Continuous red:

GSM interface error (PIN, SIM, communication)

Flashing red, 400/400 ms: no GSM net

Slowly flashing green, 200/4600 ms: line OK

Flashing green, 400/400 ms: connecting call

Continuous green: call connected

Fallback enabled

Continuous red:

GSM interface error (PIN, SIM, communication)

Flashing red, 400/400 ms:

Neither line nor GSM OK

Flashing red/green, 400/400 ms:

PSTN-line or GSM net missing

Slowly flashing green, 200/4600 ms: line OK

Flashing green, 400/400 ms: connecting call

Continuous green: call connected

Fire Mode

The SL6+ system can be used as a firefighter intercom system. Depending on the configuration, you can have up to 6 voice units as fire units.

Fire mode is started by activating an input on the main unit. Refer to the "Wiring Diagram SL6+ Main Unit" (page 12).

Configuration

Use SafeLine Pro or parameter *73* (please refer to the corresponding code in the "Parameter List") to configure the units for Fire mode.

- Set Input 1 to Fire mode: *73*14#.
- Set Input 2 to Fire mode: *73*24# - default.
- Select other voice units to be included in Fire mode with SL Pro.

Operation

Activating Fire mode does the following:

A siren sound is heard in the speaker of the main unit during the active time.

Press the reset button to stop the siren sound.

A voice message specifically for Fire mode is played. Refer to the "Distress message"-section of the "Parameter List" table.

When Fire mode is activated the units operate as intercom units only and can not make emergency calls.

Voice communication

- Voice station in the car: microphone and speaker are both active.
- Other units: the alarm button has the "Push to talk/Release to listen"-function.
- A short beep is heard when you press/release the button.
- When in Fire mode, you can use the configuration handset to participate in an intercom conversation
- The yellow pictogram lights up when Fire mode is activated.
- The green pictogram lights up when in speech mode and is out when listening.
- End Fire mode by disabling the input(1 or 2) on the main unit configured for Fire mode.

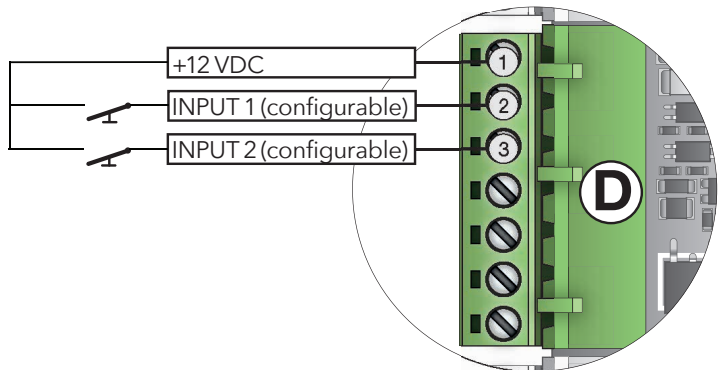

Battery Function

The expected life of a lead battery is approximately 3 years, but several factors can affect the battery's life time, e.g.:

- Ambient temperature.
- Humidity.
- Long-time storage of the battery, before powering.
- If the battery has been completely discharged for a longer period of time, it will never regain full capacity.

Battery status check

- An automatic battery status check is emitted every 7 days.
- If so configured, when the battery test fails, a battery alarm will be emitted to an alarm receiver.
- Reset the alarm by pressing the reset button.

Battery test

- If the reset button is pressed 3 times within 2 seconds, a battery test will be performed.
The battery test takes about 20 minutes.
- If the battery is low the test will be cancelled. Furthermore, when using the relay, LED 2 and the battery alarm relay will be activated. Relays can be activated for battery alarm by using parameter *88* (please refer to the corresponding code in the "Parameter List").

Cancelling the battery test

- Press the reset button once.
- LED 2 stops flashing red.
- If the battery level drops below 10,7 V, the SL6+ does not start automatically, it must be started by pressing the reset button.

Testing the battery alarm

- Unplug the battery contact during the battery status check.
- The SL6+ will now emit a battery alarm and LED 2 and battery alarm relay will be activated (if so configured).

Changing the battery

- Disconnect the 230 VAC voltage supply.
- Change the battery (article number *Batt 1,2 A).

Mains power failure

- The Mains power failure alarm is sent to the alarm receiver (SLCC) after 15 minutes of mains power failure.

Troubleshooting Main Unit

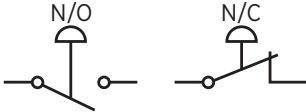
PROBLEM	POSSIBLE CAUSE(S)	SOLUTION
The unit makes an alarm call when powered up.	<ul style="list-style-type: none"> • Improper type of alarm button selected. • Alarm button is stuck. 	<p>Use SafeLine Pro or a telephone and parameter *74* and/or *89* to change from N/C (Normally closed) to N/O (Normally open) or from N/O to N/C.</p> 
The alarm start to sound directly at power-up.	<ul style="list-style-type: none"> • Output 2 is set to N/C. • Input 2 is set to N/O as default. 	<p>Place a jumper between D1 and D3, reprogram to N/O. Then remove the jumper and reboot the device.</p>
No sound transmitted from the lift car to the call receiver.		<ul style="list-style-type: none"> • Connect a normal phone (e.g. Comphone) to the socket on the main unit and make a call to the car (press "1"). Alternatively, press "0" and wait for dial tone, then dial an external call. • If the sound transmission is OK in both directions, check if your emergency operator supports the chosen alarm type. • If no protocol is used, change the call type to "VOICE" using SafeLine Pro or program with *21*..*24*.
Interfering noise when the call is connected.	<ul style="list-style-type: none"> • If the main unit is installed on the car roof, the problem might be due to induction in the phone cable. 	<ul style="list-style-type: none"> • According to the telephone companies' regulations, the phone line must be installed in a separate cable. Do a noise test (**).
GSM noise.		<ul style="list-style-type: none"> • Change the antenna position when a call is connected until you find the optimal antenna position. • Do not install the antenna near the main unit or close to the cabling.
Cannot dial out.	<ul style="list-style-type: none"> • Broken line connection (LED 3 not flashing green). • No money on refill SIM card. 	<ul style="list-style-type: none"> • Check the phone line connection (*). • Verify the SIM card by inserting it into a normal mobile phone.

* ** *** Refer to chapter "Related Test Procedures"

Troubleshooting Voice Unit

PROBLEM	POSSIBLE CAUSE(S)	SOLUTION
<p>The unit can not make an alarm call.</p>	<ul style="list-style-type: none"> • At least one phone number and/or one ID code if using data identification must be programmed to make a call from the unit. • Refer to the parameter *11*. • Button not connected. • No voice unit connected. 	<ul style="list-style-type: none"> • Check wiring. • At least one voice unit must be connected in order to make an alarm call.
<p>No voice switching.</p>	<ul style="list-style-type: none"> • If the main unit is installed on the car roof, the problem might be due to induction in the phone cable. 	<ul style="list-style-type: none"> • Place the bus cable in an environment with little external interference(***). Do a microphone test(***).
<p>The pictogram LEDs are flashing quickly and simultaneously.</p>	<ul style="list-style-type: none"> • The address switch is set to an invalid number (0, 7, 8, 9). Valid numbers are 1-6. • The address switch setting has been changed during operation. 	<ul style="list-style-type: none"> • Change the address switch to a valid number and restart the SL6 unit.
<p>The pictogram LEDs are flashing alternately.</p>	<p>Bus communication error caused by any of the following reasons:</p> <ul style="list-style-type: none"> • Two or more units have the address switch set to the same number. • Bus cable broken. • Incorrect wiring of the bus cable. 	<ul style="list-style-type: none"> • Ensure that the address switches of the units are set to different numbers. • Ensure that the bus cable is not broken. • Check the bus cable installation.
<p>The telephone beeps every 5 seconds.</p>	<p>This is to notify the passengers of the ongoing call (anti eavesdropping).</p>	<p>This is a normal procedure.</p>

* ** *** Refer to chapter "Related Test Procedures"

Related Test Procedures

* Telephone line check

1. Power up the unit.
2. Lift the configuration handset.
3. Wait for dial tone.
4. Dial "0".
5. Wait for new dial tone.
6. Call another telephone and start a normal conversation.
7. Hang up the configuration handset to end the call.

If one of these steps is not successful the problem may not be with the unit, but due to incorrect wiring or faulty/missing telephone line.

** Noise check

1. Power up the unit.
2. Lift the configuration handset.
3. Wait for dial tone.
4. Dial "0".
5. Wait for new dial tone.
6. Press a number on the keyboard.
7. The dial tone stops and you hear silence.
8. When you hear noise or humming, the problem may be due to induction in the phone cable.
9. Hang up the configuration handset to end the call.

According to the phone companies' regulations, the phone line must be installed on a separate cable.

Redirect the cable by changing its position or finding another pair that is free of distortion, or use shielded pair when available. When none of these solutions apply, install a separate cable for the telephone line.

*** Microphone check

Call in to the SL6+ and press the following numbers on the caller's phone.

1. Press "7" to activate the car's microphone.
2. Press "*" activates microphone of the caller.
3. Press "4" for automatic switching of microphones.

If you can speak through the microphones the hardware is OK.

EU Declaration of Conformity

Product: Lift telephone
 Type / model: **SL6**
 Article no: *SL6, *SL6-4G, *SL6-GSM, *SL6-GSM-BOARD, *SL6-MAINBOARD, *SL6-MINI, *SL6-MINI-4G, *SL6-MINI-GSM, *SL6 A+, *SL6 A+ MINI, *SL6 A+ 3G, *IF-BOARD-4G
Including voice stations:
 *SLB3-COP, *SLB3-REC-PIC, *SLB3-REC-PIC-B, *SLB3-SM-PIC, *SLB3-SM-PIC-B, *SLB3-SM-PIC-L, *SLB-COP, *SLB-COP2, *SLB-COP2-L, *SLB-COP-L, *SLB-COP-SEP, *SLB-IF1, *SLB-IF2, *SLB-RD, *SLB-RD-BUT, *SLB-REC, *SLB-REC-FIRE, *SLB-REC-FIRE02, *SLB-REC-FIREK, *SLB-REC-FIREK02, *SLB-REC-LED, *SLB-REC-PIC, *SLB-REC-PIC-BUT, *SLB-SM, *SLB-SM-LED, *SLB-SM-PIC, *SLB-SM-PIC-BUT, *SLB-SM-PIC-LIGH, *SLB-SMD-PIC-BUT
 Manufacturer: SafeLine Sweden AB
 Year: 2017

We herewith declare under our sole responsibility as manufacturer that the products referred to above complies with the following EC Directives:

Directives

Radio Equipment (RED): 2014/53/EU
 RoHS 2: 2011/65/EU

Standards applied

EN 81-20:2014 Lift: Safety & Technical requirements
 EN 81-28:2003 Lift: Remote alarm on passenger and goods passenger lifts
 EN 81-50:2014 Lift: Test and examination requirements
 EN 81-70:2003/A1:2004 Lift: Accessibility to lifts for persons including persons with disability
 EN 81-72:2015 Lift: Firefighters lifts
 CEN/TS 81-76 Lift: Evacuation of disabled persons using lifts (Not harmonized yet)
 EN 12015:2014 EMC: Emission, Electromagnetic compatibility
 EN 12016:2013 EMC/Lifts: Immunity, Electromagnetic compatibility
 EN 62368-1:2014/AC:2015 LVD: Information Technology Equipment
 EN 50581:2012 RoHS: Technical doc. for assessment of restriction of RoHS.

For RED 2014/53/EU, the conformity assessment procedure "Module A" used as described in Annex II. Accordingly, respective manufacturer has done the radio modules conformity assessment:

Module	Notified body	Address	NB nr	Test nr
GL865-Dual V3	DEKRA	Parque Tecnológico de Andalucía / SeveroOchoa 2,	1909	53051 RBN.001
EU V2	DEKRA	29590 Spain	1909	52382 RCB.001
CYW207325	NTS	41039 Boyce Road, Fremont, CA 94538, US	0214.26	R 104750/51

Standards applied

Standards applied	Article of Directive 2014/53/EU
EN 60950-1:2006+A11:2009+A1:2010+A12:2011+A2:2013	3.1 (a): Health and safety of the user
EN 62311:2008	
EN 301 489-1 V2.1.1 + EN 301 489-5 V1.1.0 Draft	3.1 (B): Electromagnetic Compatibility
EN 301 489-17 V3.1.1	
EN 301 511 V12.5.1	3.2: Effective use of spectrum allocated
EN 301 908-1 V11.1.1 /-2 V11.1.1 /-13 V11.1.1	
EN 300 328 V2.1.1	

Firmware used during assessment

GL865-Dual V3:	16.00.152 / 16.01.150 / 16.01.153
LE910-EU V2:	20.00.402
SafeLine SL6	4.45

Tyresö, 2017-04-07



Lars Gustafsson,
 Technical Manager, R&D, SafeLine Group



Safeline Headquarters

Antennvägen 10 · 135 48 Tyresö · Sweden
Tel.: +46 (0)8 447 79 32 · info@safeline.se
Support: +46 (0)8 448 73 90

Safeline Denmark

Erhvervsvej 19 · 2600 Glostrup · Denmark
Tel.: +45 44 91 32 72 · info-dk@safeline.se

Safeline Norway

Solbråveien 49 · 1383 Asker · Norway
Tel.: +47 94 14 14 49 · post@safeline.no

Safeline Europe

Industrieterrein 1-8 · 3290 Diest · Belgium
Tel.: +32 (0)13 664 662 · info@safeline.eu
Support: +32 (0)4 85 89 08 95

Safeline Deutschland GmbH

Kurzwannstraße 3 · D-68526 Ladenburg · Germany
Tel.: +49 (0) 6203 - 840 60 03 · sld@safeline.eu

Safeline Elevator Parts UK

3 Evegate Park Barn · Station Road
Smeeth · Ashford · Kent · TN25 6SX · United Kingdom
Tel.: +44 (0)1303 813414 · info@safeline.uk.com